

Sealed Lead Acid Battery Charger

■ Specifications

Input Voltage	100 ~ 240VAC
Input Frequency	50/60Hz
Input Current	0.5A Max any input voltage
Inrush Current	115V/40A, 230V/50A @25°C
Leakage Current	0.25mA Max @ 240VAC
Operating Temperature	0 ~ 40°C Under full load & normal operation
Safety & EMI	CE Meets EN60335 and EN55014-1
Over Current Protection	2A @ 100 ~ 240VAC
Short Circuit Protection	Present - Self-Recovery
Reverse Polarity Protection	Present - Self-Recovery

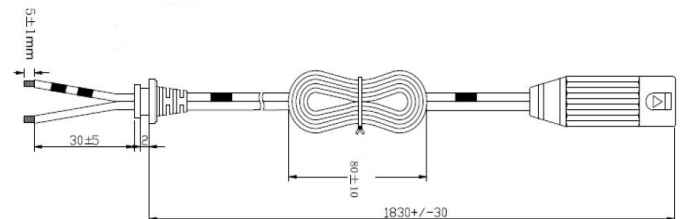
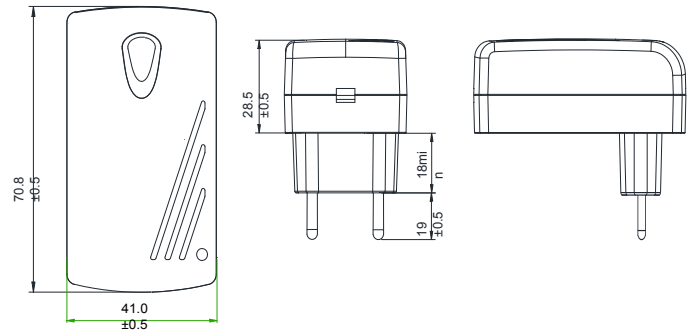

■ Output Characteristics

Voltage	14.4V
Min. Load	0A
Rated Load	1.0A
Voltage Regulation	±3%

■ Handling Precautions

- Don't immerse in water or allow it to get wet!
- Don't reverse the positive and negative polarity!
- Don't short-circuit the charger with wires or metal objects!
- Don't disassemble the charger in any way!